



COMMERCIAL METER PEDESTAL WITH CUSTOMER SECTION

- Provides metered power distribution for street lighting, park lighting, private development lighting, signage, irrigation, pump, and cellular applications
- 100% stainless steel welded construction provides ultimate protection against corrosion and vandalism
- Swingside top allows for full exposure of meter compartment
- Top is easier to open and control than fliptops, and locks out for safety
- All stainless steel enclosures may be powder coated in many colors at an additional charge
- Double Door Design
- Stainless Steel Hinge
- Weather & Vandal Resistant
- Three-Point Locking System

METER SECTION

- 200 amp load center with up to 30 circuits
- 120v, 240v and 480v models available
- Test Blocks
- UL Listed, NEMA TYPE 3R Rated
- E.U.S.E.R.C. 308 compliant commercial meter pedestal

CUSTOMER SECTION

- Unique design provides large electrical customer compartment but maintains a slim, small cabinet profile
- 18" Wide, 52" High, 20" Deep
- 20" x 30" customer electrical compartment
- Ten year limited warranty

MPS-A16-10K* Metered Enclosure

- 100 amp meter/100 amp load center
- 16 pos. with main 1 phase

MPS-B16-10K* Metered Enclosure

- 100 amp meter/150 amp load center
- 16 pos. with main 1 phase

MPS-C32-10K* Metered Enclosure

- 200 amp meter/200 amp load center
- 32 pos. with main 1 phase

MPS-D18-10K* Metered Enclosure

- 100 amp meter/100 amp load center
- 18 pos. with main 3 phase

MPS-E24-10K* Metered Enclosure

- 200 amp meter/200 amp load center
- 24 pos. with main 3 phase

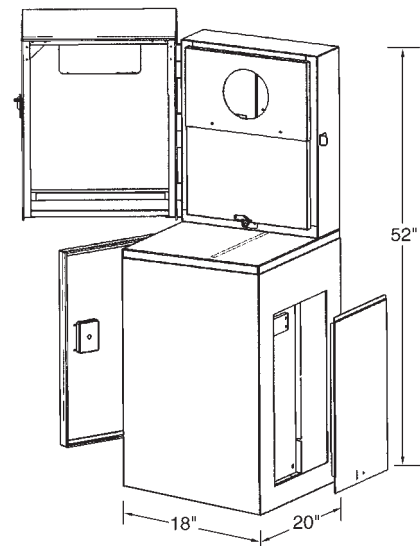

*All meter pedestals available with AIC ratings of 22k, 65k and higher.
* Photocell, time clocks, lighting contactors and circuit breakers available factory installed.*



COMBINED COMMERCIAL METER SOCKET WITH THE ULTIMATE ENCLOSURE

- Compact, double door, front and back design, provides viewing and programming convenience
- 100% stainless steel construction assures long-term, rust-proof durability and additional strength
- Chameleon effect of the natural brushed stainless steel finish provides an unobtrusive quality
- All stainless steel enclosures may be powder coated in many colors at an additional charge

METER SECTION

- UL listed, E.U.S.E.R.C. approved commercial meter socket, 100 amp rated, with test block bypass provision
- Hinged viewing window provides convenient access for metering agency
- 100 amp load center
- 120v and 240v models available

ENCLOSURE SECTION

- Removable, predrilled backboard provides for easy installation and an attractive finished product
- Large door-mounted storage area provides easy access to plans and scheduling information
- Side louvers at bottom and top allow crossflow ventilation
- Ten year limited warranty

SB-24SS/120V Metered Enclosure 120 Volt

- 24" Wide, 48" High, 29" Deep
- 120 Volt Meter Socket
- Test Blocks
- 8 Position Load Center
- Double Door Design
- 12" Deep Storage on Back Side
- 100% Stainless Steel
- Weather & Vandal Resistant
- Three-Point Locking System
- Removable, Predrilled Backboard
- Large Door-Mounted Storage
- Louvered For Ventilation
- UL Listed
- NEMA TYPE 3R Rated

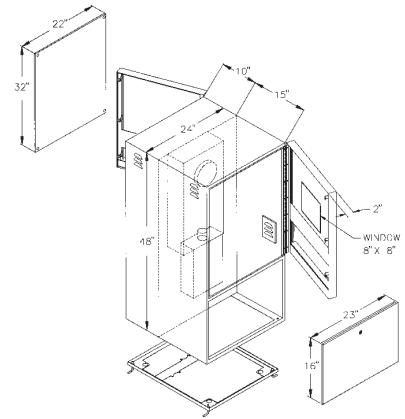

SB-24SS/240V Metered Enclosure 240 Volt

- 24" Wide, 48" High, 29" Deep
- 240 Volt Meter Socket
- Test Blocks
- 8 Position Load Center
- Double Door Design
- 12" Deep Storage on Back Side
- 100% Stainless Steel
- Weather & Vandal Resistant
- Three-Point Locking System
- Removable, Predrilled Backboard
- Large Door-Mounted Storage
- Louvered For Ventilation
- UL Listed
- NEMA TYPE 3R Rated

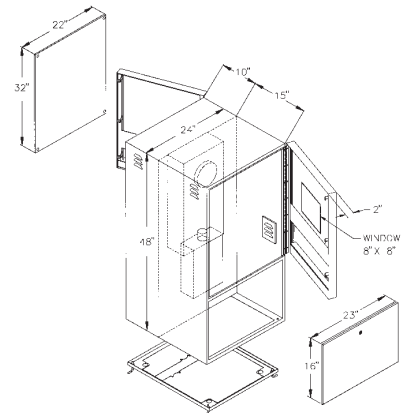



**COMBINED COMMERCIAL METER SOCKET
WITH COLD ROLLED STEEL ENCLOSURE**

- Compact, double door, front and back design, provides viewing and programming convenience
- Standard colors for powder coated enclosures are dark green and tan. All other colors are available at an extra charge

METER SECTION

- UL listed, E.U.S.E.R.C. approved commercial meter socket, 100 amp rated, with test block bypass provision
- Hinged viewing window provides convenient access for metering agency
- 100 amp load center
- 120v and 240v models available

ENCLOSURE SECTION

- Removable, predrilled backboard provides for easy installation and an attractive finished product
- Large door-mounted storage area provides easy access to plans and scheduling information
- Side louvers at bottom and top allow crossflow ventilation
- Ten year limited warranty

**SB-24CR/120V
Metered Enclosure 120 Volt**

- 24" Wide, 48" High, 29" Deep
- 120 Volt Meter Socket
- Test Blocks
- 8 Position Load Center
- Double Door Design
- 12" Deep Storage on Back Side
- Stainless Steel Hinge
- Weather & Vandal Resistant
- Three-Point Locking System
- Removable, Predrilled Backboard
- Large Door-Mounted Storage
- Louvered For Ventilation
- UL Listed
- NEMA TYPE 3R Rated

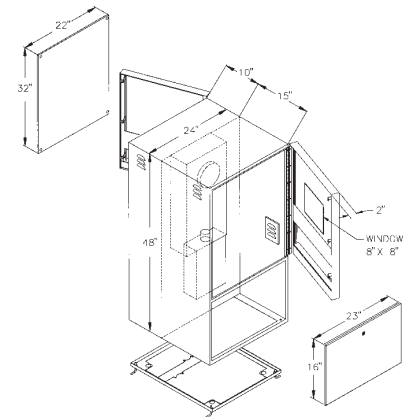

**SB-24CR/240V
Metered Enclosure 240 Volt**

- 24" Wide, 48" High, 29" Deep
- 240 Volt Meter Socket
- Test Blocks
- 8 Position Load Center
- Double Door Design
- 12" Deep Storage on Back Side
- Stainless Steel Hinge
- Weather & Vandal Resistant
- Three-Point Locking System
- Removable, Predrilled Backboard
- Large Door-Mounted Storage
- Louvered For Ventilation
- UL Listed
- NEMA TYPE 3R Rated

