



VANDAL-RESISTANT EASY ACCESS BACKFLOW ENCLOSURE

- Marine grade aluminum alloy construction provides lasting durability and strength, with light weight for ease of handling
- 100% stainless steel hardware assures long-term, rust proof durability and additional strength
- Full release locking mechanism requires no tools and provides easy access for service and repair
- Flush-mounted locking mechanism and solid sheet construction ensures maximum security
- Chameleon effect of the natural finish provides an unobtrusive quality
- Pre-punched viewing ports provide for easy inspection without removing the cover
- Expansion module allows for length adjustments to meet field requirements
- Five year limited warranty
- All aluminum enclosures may be powder coated in many colors at an extra charge

Low Profile Enclosure

	"A" Length	Height	Width
SBBC-15AL	15"	29.5"	16.25"
SBBC-30AL	30"	29.5"	16.25"
SBBC-45AL	45"	29.5"	16.25"
SBBC-60AL	60"	29.5"	16.25"

Note: For inside dimensions, see Backflow Cover Sizing Chart on page 18.

- Marine Grade Aluminum
- Stainless Steel Hardware
- Weather Resistant
- Patented Locking System Accepts Padlock
- Removable Without Tools

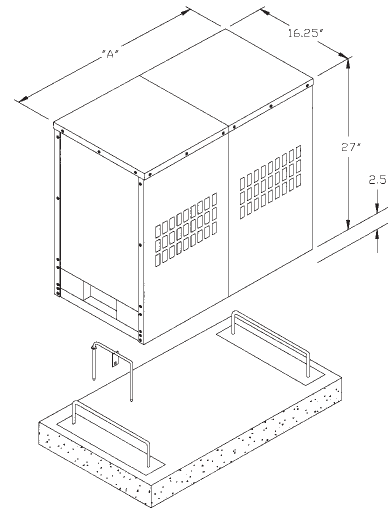

High Profile Two Piece Enclosure

	"A" Length	Height	Width
SBBC-40ALHP	40"	39"	24"
SBBC-60ALHP	60"	39"	24"
SBBC-75ALHP	75"	39"	24"
SBBC-90ALHP	90"	39"	24"

Note: For inside dimensions, see Backflow Cover Sizing Chart on page 18.

- Marine Grade Aluminum
- Stainless Steel Hardware
- Weather Resistant
- Patented Locking System Accepts Padlock
- Removable Without Tools

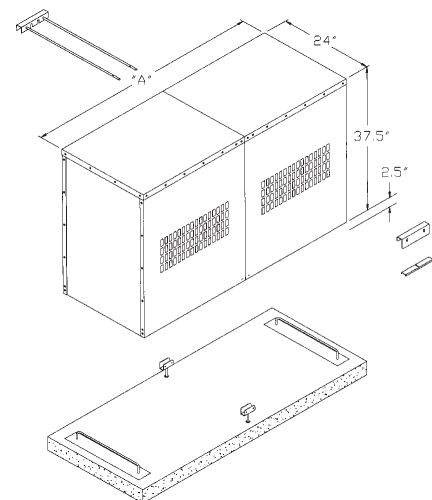



ALL WEATHER INSULATED BACKFLOW ENCLOSURE

- Marine grade aluminum alloy construction provides lasting durability and strength, with light weight for ease of handling
- 100% stainless steel hardware assures long-term, rust proof durability and additional strength
- Full release locking mechanism requires no tools and provides easy access for service and repair
- Flush-mounted locking mechanism and solid sheet construction ensures maximum security
- Chameleon effect of the natural finish provides an unobtrusive quality
- R-6 insulation on the top and sides helps protect from freezing*
- Flexible rubber skirt provides protection from wind but allows drainage
- Five year limited warranty
- All aluminum enclosures may be powder coated in many colors at an extra charge

*To properly protect from freezing, the use of pipe heating cable is recommended

Low Profile Insulated Enclosure

	"A" Length	Height	Width
SBBC-15ALI	15"	29.5"	16.25"
SBBC-30ALI	30"	29.5"	16.25"
SBBC-45ALI	45"	29.5"	16.25"
SBBC-60ALI	60"	29.5"	16.25"

Note: For inside dimensions, see Backflow Cover Sizing Chart on page 18.

- Marine Grade Aluminum
- Stainless Steel Hardware
- Weather Resistant
- Patented Locking System Accepts Padlock

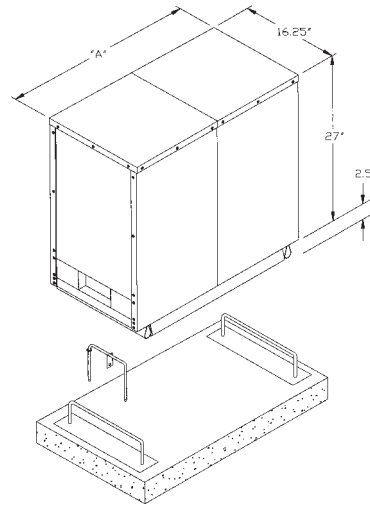

High Profile Insulated Two Piece Enclosure

	"A" Length	Height	Width
SBBC-40ALHPI	40"	39"	24"
SBBC-60ALHPI	60"	39"	24"
SBBC-75ALHPI	75"	39"	24"
SBBC-90ALHPI	90"	39"	24"

Note: For inside dimensions, see Backflow Cover Sizing Chart on page 18.

- Marine Grade Aluminum
- Stainless Steel Hardware
- Weather Resistant
- Patented Locking System Accepts Padlock

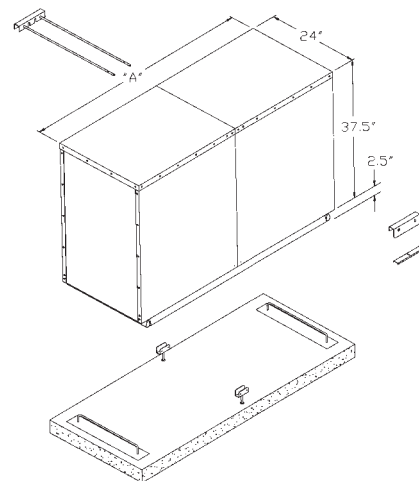



VANDAL-RESISTANT EASY ACCESS PUMP & POWER CONDITIONERS ENCLOSURE

- Marine grade aluminum alloy construction provides lasting durability and strength, with light weight for ease of handling
- 100% stainless steel hardware assures long-term, rust proof durability and additional strength
- Full release locking mechanism requires no tools and provides easy access for service and repair
- Flush-mounted locking mechanism and solid sheet construction ensures maximum security
- Chameleon effect of the natural finish provides an unobtrusive quality
- Five year limited warranty
- All aluminum enclosures may be powder coated in many colors at an extra charge

Power Conditioner Enclosure

	"A" Length	Height	Width
SBBC-40ALHPPC	40"	39"	24"

- Marine Grade Aluminum
- Stainless Steel Hardware
- Weather Resistant
- Patented Locking System Accepts Padlock
- Removable Without Tools

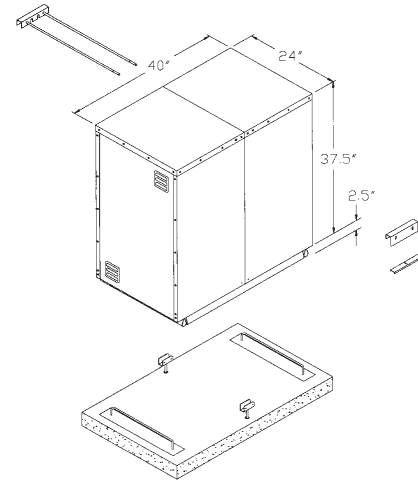

Pump Enclosure

	"A" Length	Height	Width
PE-40AL	40"	39"	38"
PE-60AL	60"	39"	38"

- Marine Grade Aluminum
- Stainless Steel Hardware
- Weather Resistant
- Patented Locking System Accepts Padlock
- Removable Without Tools

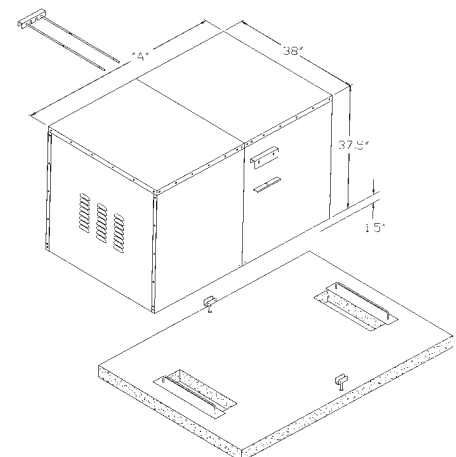



**SMOOTH TOUCH™ VANDAL RESISTANT
BACKFLOW ENCLOSURE**

- Tube and wire construction provides a smooth surface to protect against handling injury
- Architectural lines of the enclosure blend beautifully into the landscape environment
- 100% stainless steel construction assures long-term, rustproof durability and additional strength
- Full release locking mechanism requires no tools and provides easy access for service and repair
- Ten year limited warranty
- All stainless steel enclosures may be powder coated in many colors at an extra charge

Low Profile Smooth Touch™ Enclosure

	"A" Length	Height	Width
SBBC-30SS	31.5"	29.5"	17.75"
SBBC-45SS	46.5"	29.5"	17.75"

Note: For inside dimensions, see Backflow Cover Sizing Chart on page 18.

- 100% Stainless Steel
- Stainless Steel Hardware
- Weather Resistant
- Patented Locking System Accepts Padlock
- Removable Without Tools
- Minimal Surface Area Deters Graffiti

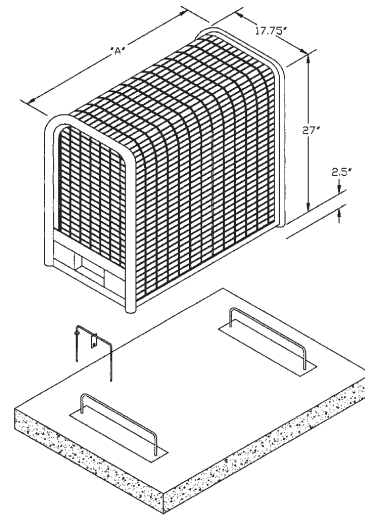

High Profile Smooth Touch™ Enclosure

	"A" Length	Height	Width
SBBC-20SS	20"	46.5"	17.75"
SBBC-40SS	40"	39"	25.5"
SBBC-75SS	76.5"	39"	25.5"

Note: For inside dimensions, see Backflow Cover Sizing Chart on page 18.

- 100% Stainless Steel
- Stainless Steel Hardware
- Weather Resistant
- Patented Locking System Accepts Padlock
- Removable Without Tools
- Minimal Surface Area Deters Graffiti

